

Features

- Peak equivalent, true RMS or true peak output
- Optional dynamic signal output
- Corrosion resistant
- Hermetic seal
- ESD protection
- Overload protection
- Reverse wiring protection

Benefits

- Choice of output: RMS, equivalent peak, and true peak; permits you to choose the sensor that best fits your industrial requirements
- Provides continuous trending of overall machine vibration
- Can help guide maintenance
- Dynamic signal output can allow spectral vibration measurements using the sensing element of the 4-20 mA sensor for comparisons

The 4-20 mA output of the PC421 Series is proportional to vibration. An output of 4 mA indicates a level of 0 ips or no vibration present for velocity output models and 0 g for acceleration output models. A full-scale reading of 20 mA indicates that the maximum range (RMS, Equivalent Peak or True Peak) of vibration is present.

The Dynamic signal output is an optional addition. Any of the base sensor models can also have dynamic signal output. Adding -DA to a model specifies a dynamic acceleration signal output (100 mV/g). Adding -DV to a model specifies a dynamic velocity signal output (100 mV/ips).

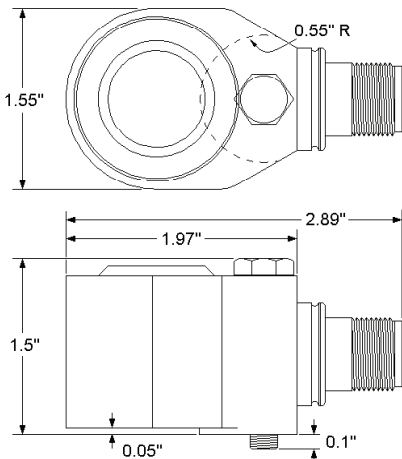

Model PC421 xxx-yy-Dz-series

Side exit, 4-20mA, loop-powered sensors (LPS)

Output, 4-20 mA

Full scale, 20 mA ($\pm 5\%$)	see Table 1 on back
Frequency response:	
$\pm 10\%$	10 Hz - 1.0 kHz
± 3 dB	4 Hz - 2 kHz
Repeatability	$\pm 2\%$
Transverse sensitivity, max.	5%

Output, dynamic

	PC421xxx-yy-DA	PC421xxx-yy-DV
Sensitivity ($\pm 10\%$)	100 mV/g	100 mV/ ips
Full scale	20g, peak	1.5 ips @ 1kHz
Frequency response:		
± 3 dB	2.5 Hz - 10 kHz	2.5 Hz - 2.5 kHz
Amplitude nonlinearity, maximum	1%	
Resonant frequency, mounted, nominal	21 kHz	
Transverse sensitivity, max.	5%	

Electrical

Power requirements (Two wire loop power):

Voltage (between pins A & B)	10 VDC min, 30 VDC max
Loop resistance ¹ at 24 VDC, maximum	700 Ω
Turn on time, 4-20 mA loop	30 seconds
Grounding	case isolated, internally shielded

Environmental

Temperature range	-40 to 85°C
Vibration limit	250 g peak
Shock limit	2,500 g peak
Sealing	hermetic

Physical

Sensing element design	PZT ceramic / shear
Weight	320 grams
Case material	316L stainless steel
Mounting	1/4 - 28 captive bolt
Outut connector:	
PC421xxx-yy	2 pin, MIL-C-5015 style
PC421xxx-yy-Dz	3 pin, MIL-C-5015 style
Mating connector:	
PC421xxx-yy	R6 type
PC421xxx-yy-Dz	R6G type
Recommended cabling:	
PC421xxx-yy	J9T2A
PC421xxx-yy-Dz	J9T3A

See back for notes.

Wilcoxon Research Inc
 21 Firstfield Rd
 Gaithersburg, MD 20878
 USA

Tel: 301 330 8811
 Fax: 301 330 8873
 Email: sensors@wilcoxon.com

www.meggitt.com

MEGGITT
 smart engineering for
 extreme environments

PC421xxx-yy	PC421xxx-yy-Dz	
Connector pin	Connector pin	Function
Shell	shell	ground
A	A	loop positive (+)
B	B	loop negative (-)
N/C	C	dynamic signal

Notes: ¹ maximum loop resistance (RL) can be calculated by:

$$R_L \text{ (max. resistance)} = \frac{V_{DC \text{ power}} - 10 \text{ V}}{20 \text{ mA}}$$

DC Supply Voltage	R _L (max resistance) ²	R _L (minimum wattage capability) ³
12 VDC	100Ω	1/8 Watt
20 VDC	500Ω	1/4 Watt
24 VDC	700Ω	1/2 Watt
26 VDC	800Ω	1/2 Watt
30 VDC	1.0kΩ	1/2 Watt

² Lower resistance is allowed, greater than 10Ω recommended

³ Minimum R_L wattage determined by: (0.0004 x R_L)

Table 1: PC421xxx-yy-Dz Model Number Selection

xxx (4-20 mA output type)	-yy (full scale)	-Dz (dynamic output) ^A
AR = acceleration, RMS AP = acceleration, equivalent peak B ATP = acceleration, true peak C	-05 = 5 g [49 m/sec ²] -10 = 10 g [98 m/sec ²] -20 = 20 g [196 m/sec ²]	-DA = dynamic acceleration 100 mV/g [10.2 mV/ m/sec ²] -DV = dynamic velocity 100 mV/ips [3.94 mV/ mm/sec]
VR = velocity, RMS VP = velocity, equivalent peak B VTP = velocity, true peak C	-05 = 0.5 i.p.s. [12.8 mm/sec] -10 = 1.0 i.p.s. [25.4 mm/sec] -20 = 2.0 i.p.s. [50.8 mm/sec] -30 = 3.0 i.p.s. [76.2 mm/sec] -50 = 5.0 i.p.s. [127 mm/sec]	-DA = dynamic acceleration 100 mV/g [10.2 mV/ m/sec ²] -DV = dynamic velocity 100 mV/ips [3.94 mV/ mm/sec]

^A **Dynamic output is an option on all models.** If dynamic output option is not desired, do not add -DA or -DV to the model number.

^B **Equivalent peak output is developed based on the true RMS value of vibration.** For a pure sine wave, the equivalent peak output is 1.414 times the RMS value.

^C **True peak output is based on the actual measured peak value using the time waveform and is not based on the RMS calculation.**

PC421xxx-yy WIRING

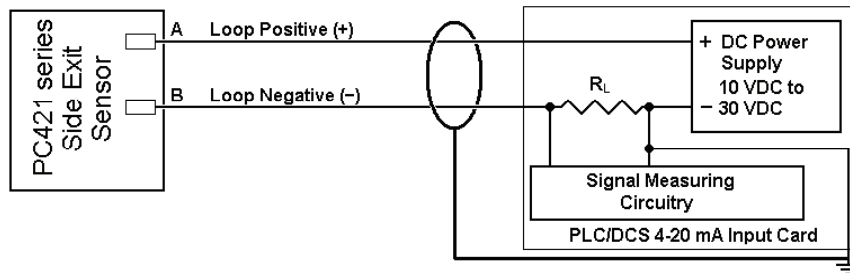

PC421xxx-yy-Dz WIRING

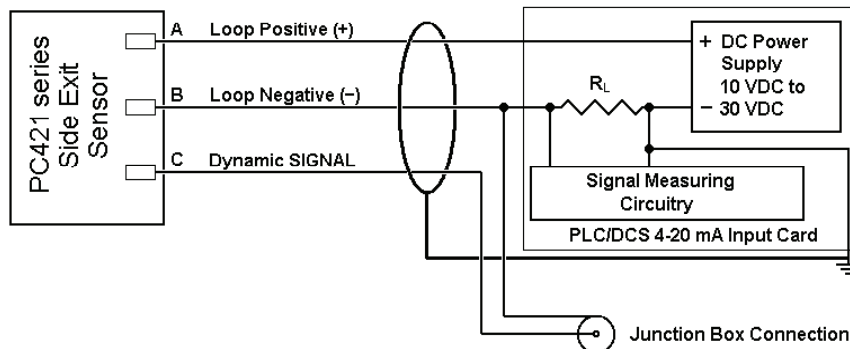

All wire and cable used for installation of the PC421-series sensor should be shielded. Generally accepted instrumentation wiring practice considers the best way to ground the shield is to connect it at the measurement end of the cable. The shield should not be wired to ground at the sensor end of the cable. Wilcoxon R6W, R6GQAI, R6GQI and R6QI type connectors all leave the shield unconnected at the sensor end of the cable.