

Variable Reluctance Speed Sensor with Amplifier

EV58AM

GREEN LINE
INDUSTRIAL SPEED SENSORS

Product ID

Type #	Product #	Drawing #
EV58AM	385Z-05662	114.780 Rev.0

General

Function	The EV58AM series variable reluctance (VR) speed sensors consist of an iron core, an inductive coil, and a permanent magnet and an amplifier. A ferrous pole wheel passing the sensor face changes the magnetic field strength, resulting in an AC voltage being induced in the coil. This signal is converted to a square wave signal with constant amplitude by the integrated amplifier. The frequency of the output signal is proportional to the speed of the moving target.
----------	---

Technical data

Supply voltage	5...32 VDC, protected against reverse polarity
Current consumption	Max. 5 mA (without load)
Coil properties	<ul style="list-style-type: none"> • Inductance @ 1 kHz: 170 mH ± 10% • Resistance: 850 Ohm ± 10% • Magnet polarity: north pole towards front face • Pole piece: diameter 2.7 mm
Polarity	Upon approach of ferrous metal, the signal pin is positive with respect to GND.
Signal output	Square wave signal from NPN output transistor with internal 2.2 kOhm pull-up resistor, DC-coupled to supply (negative pole = reference voltage). The signal frequency is proportional to the target speed. The signal amplitude does not depend on air gap and target geometry.
Frequency range	Up to 20 kHz, lower limit depending on application
Housing	5/8"-18 UNF-2A, tightening torque: max. 35 Nm
Connection	Connector mates with straight plug MS3106A-10SL-3S, 3 pins
Protection	Sensor head: IP68 Connector: IP67
Insulation	Housing and electronics galvanically isolated (Test: 500 V, 50 Hz for 1 minute)
Pole wheel	Prerequisite: Toothed wheel of a ferrous material (e.g. Steel 1.0036). Optimal performance with <ul style="list-style-type: none"> • Involute gear • Tooth width > 10 mm • Side offset < 0.2 mm • Eccentricity < 0.2 mm
Air gap between sensor and pole wheel	Depending on lowest circumferential speed which has to be detected. Typically in the order of 1 mm.
Electromagnetic compatibility (EMC)	Please contact Jaquet for further details.
Vibration & shock immunity	Jaquet Greenline sensors are approved for rough environments. Please contact Jaquet for further details.
Operating temperature	-40°C...125°C

Further Information

Safety	All mechanical installations must be carried out by an expert. General safety requirements have to be met.
Installation	<p>The sensor has to be aligned to the pole wheel according to the sensor drawing independent of its rotational orientation. Deviations in positioning may affect the performance and decrease the noise immunity of the sensor. During installation, the smallest possible pole wheel to sensor gap should be set. The gap should however be set to prevent the face of the sensor ever touching the pole wheel. The amplitude of the output signal is not influenced by the air gap.</p> <p>A sensor should be mounted with the middle of the face side over the middle of the pole wheel. Dependent upon the wheel width, a certain degree of axial movement is permissible. However, the middle of the sensor must be at minimum in a distance of 3 mm from the edge of the pole wheel under all operating conditions.</p> <p>A solid and vibration free mounting of the sensor is important. Eventual sensor vibration relative to the pole wheel can induce additional output pulses. The sensors are insensitive to oil, grease etc. and can be installed in arduous conditions.</p>
Maintenance	Product cannot be repaired.
Transport	Product must be handled with care to prevent damage of the front face.
Storage	Product must be stored in dry conditions. The storage temperature corresponds to the operation temperature.
Disposal	Product must be disposed of properly, it must not be disposed as domestic waste.

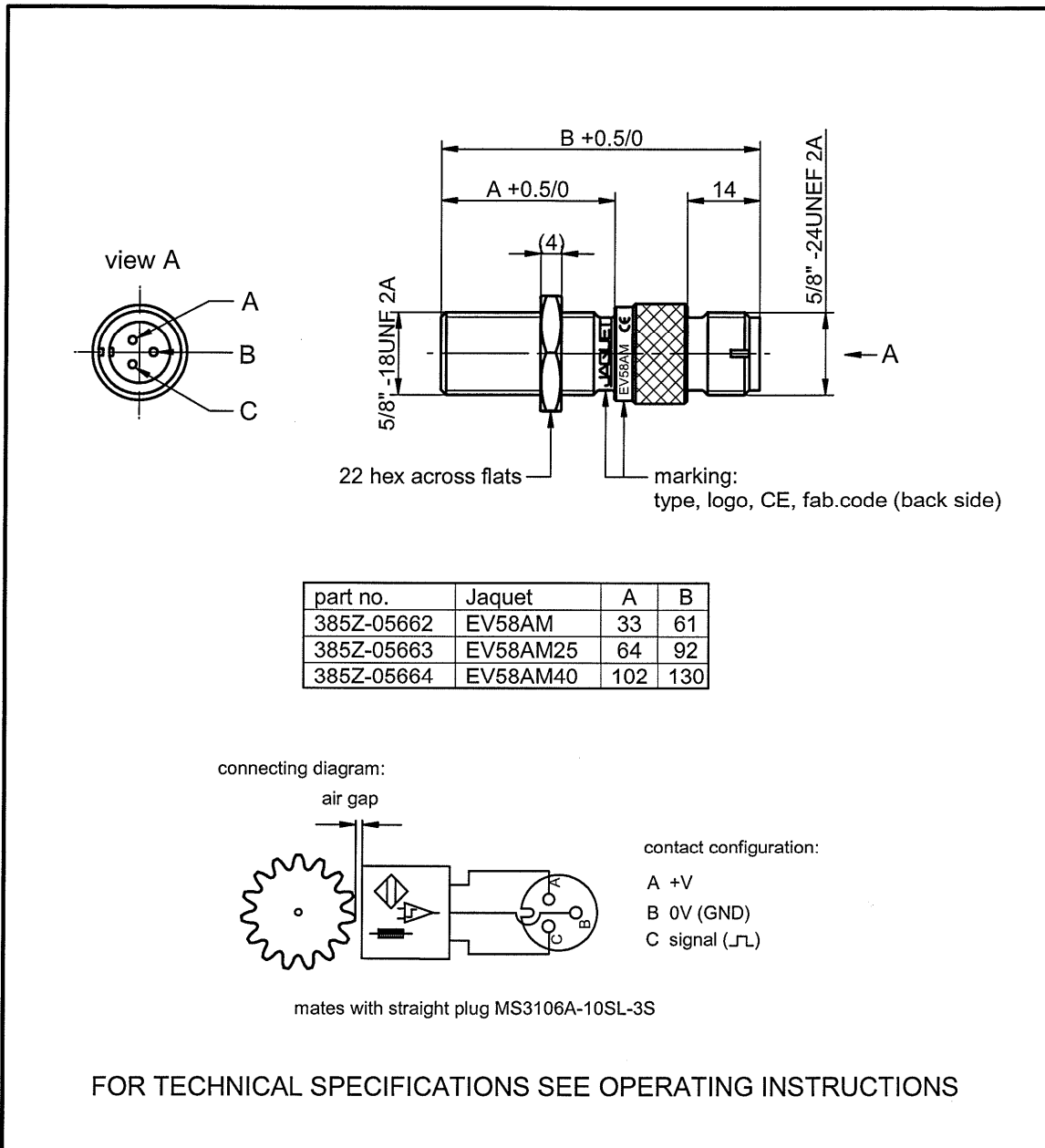

part no.	Jaquet	A	B
385Z-05662	EV58AM	33	61
385Z-05663	EV58AM25	64	92
385Z-05664	EV58AM40	102	130

connecting diagram:

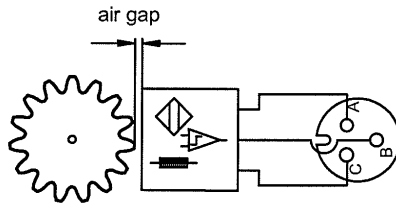

contact configuration:

- A +V
- B 0V (GND)
- C signal (L)

mates with straight plug MS3106A-10SL-3S

FOR TECHNICAL SPECIFICATIONS SEE OPERATING INSTRUCTIONS

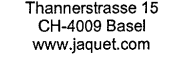
dimensions in mm			
part no.	material / remarks		application
-	-	-/-	-
-	-	-/-	-
-	-	-/-	-
-	-	-/-	-
-	-	-/-	-
rev.	ecn.	date/signature	change description
			
part name		speed sensor EV58AM	
 <p>Thannerstrasse 15 CH-4009 Basel www.jaquet.com</p>		<p>scale 1:1</p> <p>format A4</p> <p>file name 114780_rev0.dft</p>	
<p>application</p> <p>nominal size range</p> <p>allowed tolerance</p> <p>replacement for</p>		<p>first angle projection</p> <p>drawn 06.06.2007 ebi</p> <p>approved 09.08.2007 <i>Wu</i></p> <p>drawing no. 114.780</p> <p>rev. 0</p>	